



# Installation Manual

## e-Level™: TouchPad™ Controller

### Congratulations!

Thank you for purchasing the revolutionary e-Level™ system by AccuAir.

This system manages the height of up to 4 Air Springs and offers never before seen accuracy in all applications by constantly learning your vehicle's characteristics. Through the use of advanced height monitoring techniques, this system automatically corrects for changes in load, whether driving or parked, minimizing user input and maximizing accuracy throughout your driving experience. To enhance the entire system's performance and reliability, the AccuAir e-Level™ also manages your Air Compressor(s) to keep onboard air at an ideal pressure for your application.

To maximize functionality, the AccuAir e-Level™ allows you to select from three distinct vehicle heights through a TouchPad™ Controller:

- 1.) **Ride Height** (The height that you will typically drive your vehicle at).
- 2.) **Low/Cruise** (Typically set at 10% of your total suspension travel).
- 3.) **High/Extra Clearance** (Typically set at 90% of your total suspension travel to increase mobility and clear driving obstacles).

At AccuAir, we pride ourselves on thorough customer service, quality products, and a better driving experience through technologically superior design. Please visit our website or call us toll free to let us know if there is any way that we can help improve your AccuAir experience.

**(877) AIR-DOWN**  
**247-3 6 9 6**

**[www.accuaircs.com](http://www.accuaircs.com)**



## Table Of Contents

<u>Description</u>	<u>Page Number</u>
Terms & Conditions	3
Wiring Diagram	4-5
Installation Overview	6
Mounting & Wiring Instructions	7-12
Testing Mechanical & Electrical Hookup	13
Ride Height Sensor Installation	14-20
Setup Programming	21
Mounting Templates	22-28

## Terms & Conditions:

AccuAir Control Systems, L.L.C. is hereby referred to as **ACCUAIR**. The Purchaser, end-user, or installer is hereby referred to as **CUSTOMER**.

### Warranty

**ACCUAIR** will repair or replace any failed components for the life of the vehicle given that the components were installed and operated as intended by **ACCUAIR**. Upon the return of a failed component(s), **ACCUAIR** will determine the cause of failure. If it is due to improper installation, or misuse of the system, a repair charge will be assessed and the customer will be contacted before work is performed or replacement parts are shipped. If the failure is due to faulty parts, then **ACCUAIR** will repair or replace the failed components at their own discretion and in a timely manner.

### Repairs and Returns

A Return Merchandise Authorization Number (RMA) is required for ALL shipments to AccuAir Control Systems. This number should be written in large letters on the shipping box. Call AccuAir to receive an RMA number and send items to:

**AccuAir Control Systems, L.L.C.**  
**Attn: Service Department/RMA # \_\_\_\_\_**  
**1241 Johnson Ave. #355**  
**San Luis Obispo, Ca, 93401**  
**USA**

### Legal Disclaimer

- **ACCUAIR's** products must be installed by a qualified professional installation facility as recommended by **ACCUAIR**.
- System operation and installation is at the **CUSTOMER's** own risk. **ACCUAIR** accepts no liability for damage of property or persons caused by its products, components, accessories, installation instructions or otherwise.
- **ACCUAIR** accepts no responsibility for systems, products or components provided by other manufacturers for use with or around the **ACCUAIR** system. For components other than **ACCUAIR's**, follow the manufacturer's instructions for installation and operation.



**WARNING: No part of the vehicle should be able to contact the ground when all air is out of the air springs.**

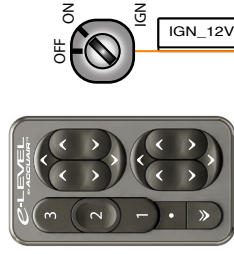

TouchPad™  
Controller

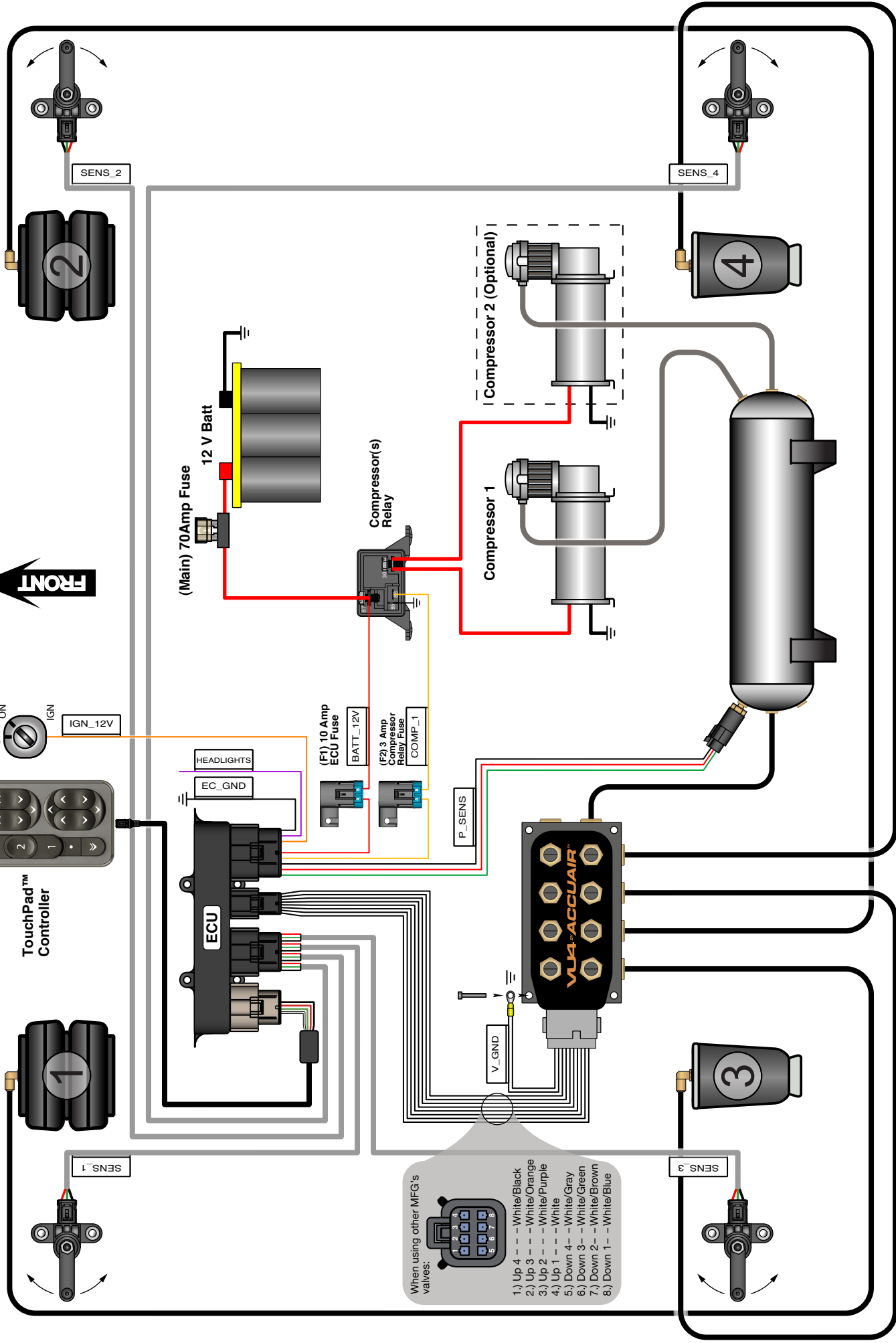

When using other MFG's valves:

- 1) Up 4 - - - White/Black
- 2) Up 3 - - - White/Orange
- 3) Up 2 - - - White/Purple
- 4) Up 1 - - - White
- 5) Down 4 - - White/Gray
- 6) Down 3 - - White/Green
- 7) Down 2 - - White/Brown
- 8) Down 1 - - White/Blue

## Installation Overview:

After your Air Springs and Suspension Components have been installed, you can begin installing the AccuAir components in the following order:

- 1.) Install VU4 (Valve Unit)
- 2.) Install ECU (Electronic Control Unit)
- 3.) Install TouchPad™ Controller
- 4.) Install Tank Pressure Sensor
- 5.) Install Air Compressor(s)
- 6.) Install Wiring Harnesses
- 7.) Test Wiring and Mechanical Components
- 8.) Install Ride Height Sensors
- 9.) **CALIBRATE SYSTEM**



**WARNING: Make sure to disconnect the vehicle battery ground terminal throughout the wiring process.**

## VU4 (Valve Unit) Mounting:

### Valve Mounting Considerations

- These valves are 100% weather-proof and can be mounted under vehicle.
- You will need to mount the ECU near the valves, so make sure that there is enough space for both items.

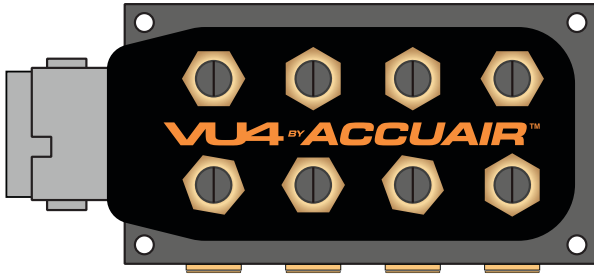

### Step-by-Step

- 1.) Find a flat location to mount the VU4. This should allow enough room for the airlines to be inserted without too much bending.
- 2.) Transfer hole pattern from the **VU4 Mounting Template** on page 22.
- 3.) Drill holes with a 3/16" drill bit and bolt the VU4 down with the included #10-24 Allen head cap screws.
- 4.) Place the ground eyelet from the VU4 wiring harness under one of the cap-screws and make sure that this screw has good contact to chassis ground. (Remove paint or coatings to expose bare metal)
- 5.) You may use this same location to place the ECU ground, so do not tighten yet.

### Ground Eyelet Installation

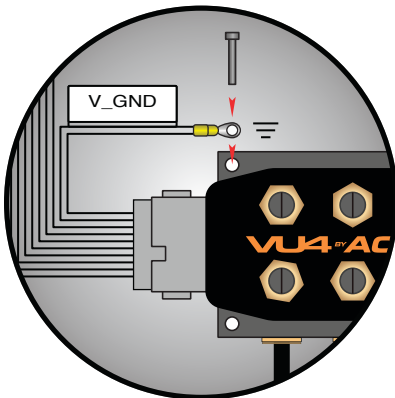

### Wire Color Description

When using other MFG's valves:



- 1.) Up 4 — — — — White/Black
- 2.) Up 3 — — — — White/Orange
- 3.) Up 2 — — — — White/Purple
- 4.) Up 1 — — — — White
- 5.) Down 4 — — — — White/Gray
- 6.) Down 3 — — — — White/Green
- 7.) Down 2 — — — — White/Brown
- 8.) Down 1 — — — — White/Blue

## ECU Mounting:

### **ECU Mounting Considerations**

- The ECU is 100% weather-proof and can be mounted under vehicle next to the valves.
- The ECU can be mounted upright or on its back as seen below. (If back mounted, back tabs must be removed)
- The following diagrams illustrate both “Standard” and “Optional” mounting configurations.

**Bottom Mounting (Standard):**  
*See ECU Mounting Template on page 24.*

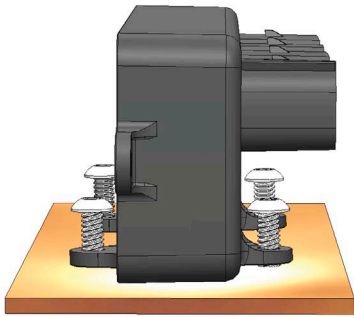

**Back Mounting (Optional):**  
*See ECU Mounting Template on page 26.*

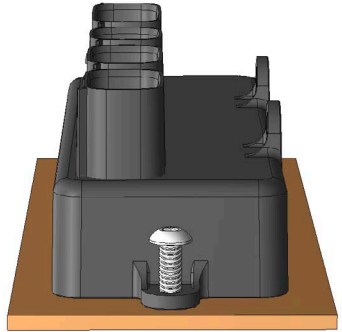

### **Step-by-Step**

- 1.) Find a flat location near the VU4 (Valve Unit) to mount the ECU.
- 2.) Plug-In the Valve Harness while finding the mounting position to make sure that it reaches.
- 3.) Transfer hole pattern from the ***ECU Mounting Template*** on pages 24 & 26.
- 4.) Drill holes with a 3/16” drill bit and bolt the ECU down with the included #10-32 Allen head cap screws.

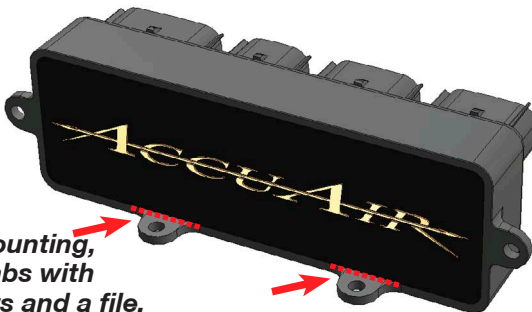

***For optional mounting,  
remove back tabs with  
diagonal cutters and a file.***



## Pressure Sensor Mounting:

### **Tank Pressure Sensor Mounting Considerations**

- Mount the Pressure Sensor vertically with the threads aiming downward to avoid moisture build up in the sensor.
- Mount the Sensor close to the ECU to connect the pre-terminated sensor harness that is part of the Main ECU Harness.

**Example 1:**  
**Pressure Sensor Mounting.**  
**(In the top of the tank)**

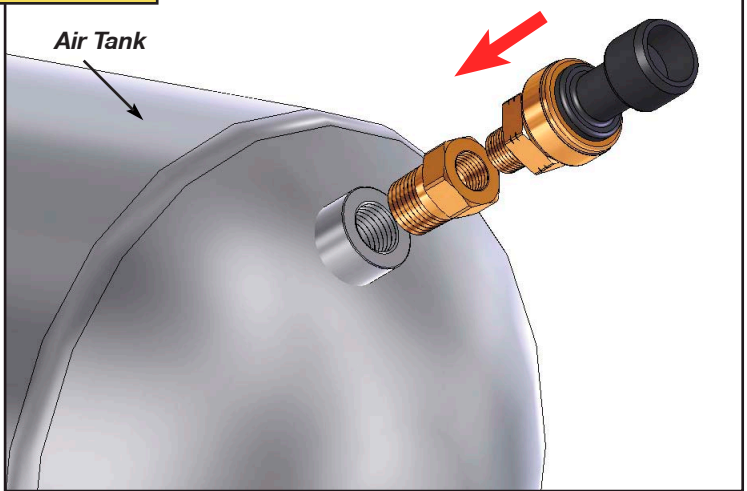

**⚠ WARNING: e-Level™ System is NOT compatible with any other Pressure Sensor or Switch.**

### **Step-By-Step**

- 1.) Coat the threads of the Sensor and any threaded fitting or adapter used in the air supply system with a thread sealer to help prevent air leaks. We recommend a liquid thread sealer for best results but Teflon tape will work also. We strongly recommend an Anaerobic Thread Sealer such as **Loctite's (P/N: 565)**
- 2.) After tightening the sensor wipe off the excess thread sealer.





## Installing & Wiring Air Compressor(s):

### **Air Compressor(s) Mounting Considerations**

- There should be a fuse in between the Compressor(s) and the battery.
- The Compressor(s) get very **HOT** during operation. Make sure to leave space between items that are susceptible to heat. (Wires, Nylon-Air Line, etc.)

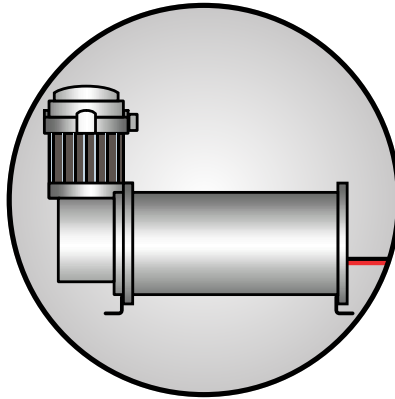

### **Step-By-Step**

- 1.) Find a location for the Compressor(s) to be mounted with good air circulation.
- 2.) Transfer the hole pattern of the Compressor using the Air Compressor as your template.
- 3.) Drill holes and bolt the Air Compressor(s) down.
- 4.) Install the Power Wire to the vehicle battery (12v+) with an inline fuse (30amps per Compressor) that is included with your Compressor(s) near the vehicle battery (12v+).
- 5.) Install the Compressor Relay inline with the Compressor's power line.
- 6.) Install the Ground Wire to vehicle/chassis ground. (Make sure to remove any rust or paint to ensure a thorough ground)

## Install Wiring Harnesses:

### **Wiring Harness Installation Considerations**

- The plugs that connect to the ECU will only fit in the desired orientation. Do not force the connectors into the wrong mating connector.
- Make sure to press all connectors on firmly until an audible “click” sound can be heard from the lock.
- Route all wiring away from exhaust or other hi-temp areas.
- Use Rubber Grommets for areas where sharp metal could eventually wear through the wire insulation.

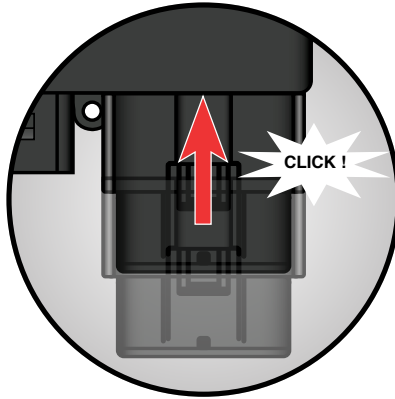

*See System Diagram  
on pages 4-5.*

### **Step-By-Step**

#### **•ECU Main Harness**

- 1.) First connect the Main Harness at the ECU then route each section to each component on the vehicle.
- 2.) Route the Touchpad™ harness (Mini USB Cable) to the inside of the vehicle and leave until later in installation. Route the single purple wire labeled “HEAD-LIGHTS” to a 12V source in the vehicle Headlight Switch. Check the manufacturer’s specs for a 12V Headlight source inside the vehicle (You can also use a 12V wire from the closest marker light instead of running it to the Headlight Switch inside the vehicle.). This will allow the TouchPad™ Controller’s backlighting to dim automatically when the headlights are on.
- 3.) Route the single orange wire labeled “IGN\_12V” to an ignition source.
- 4.) Route the 3-wire Tank Pressure Sensor sub harness (green, red, and black wires) labeled “P\_SENS” to the sensor.
- 5.) Route the single yellow wire labeled “COMP\_1” with a 3 Amp fuse to trigger the Compressor Relay(s).
- 6.) Route the single red wire labeled “BATT\_12V” with a 10 Amp fuse to the vehicle battery.
- 7.) Mount the single black wire labeled “EC\_GND” with the VU4 ground.

## TouchPad™ Controller Mounting:

### **TouchPad™ Controller Mounting**

- Choose a mounting location that will allow the driver to operate and view the TouchPad™ Controller from the driver's seat. Once your target mounting position has been found, use the template to drill mounting holes.

**NOTE: See Mounting Template on page 28.**



## Testing Wiring & Mechanical Components:

Now that the majority of your system components are installed, plumbed, and wired (Mechanical Air Suspension Components, Compressor(s), Tank(s), Tank Pressure Sensor, Valves, Air Line, ECU, and TouchPad™ Controller), it is time to test the system and begin the height sensor installation.

**NOTE: This process can be done manually with jacks or electronically using the following instructions.**



### To Begin Testing The System:

Turn the vehicle Ignition ON, or start the vehicle. (You will need to be charging your electrical system either by running the vehicle or by using a high amperage battery charger). The Air Compressor(s) will turn ON and begin filling the Tank(s). Wait until the system reaches max pressure and turns the Air Compressor(s) OFF. This process can take from 1-8 minutes depending on the size of your Compressor(s) and Tank(s).

As you consume air pressure by raising the vehicle, the Air Compressor(s) will automatically turn ON when necessary.

This is a good time to do some mechanical system checking:

Look for mechanical interference throughout the range of travel for the Air Springs and all moving suspension components.

Test for air leaks at all fittings and pipe threaded joints using a soapy spray bottle. To fix any air leaks first lower the Air Springs, then turn the Ignition OFF and depressurize the Air Storage Tank(s).

## Height Sensor Installation:

**⚠ DANGER: Sensor installation requires viewing suspension movement from underneath the vehicle. This must be done on a lift with ramps for safety. Do not attempt to get under the vehicle while it is on the ground or on jack stands for this process!!!**

Understanding suspension movement is the key to sensor mounting. The term “vertical travel” means the amount of up and down distance that a point on a suspension arm moves as it rotates. Realize that there is no “vertical travel” at the arm’s pivot point. If you mount a sensor very close to a pivot point it will barely travel at all. If you mount a sensor too far out on an arm, it will travel too far and damage the sensor. See the following diagram for an illustration of this theory:

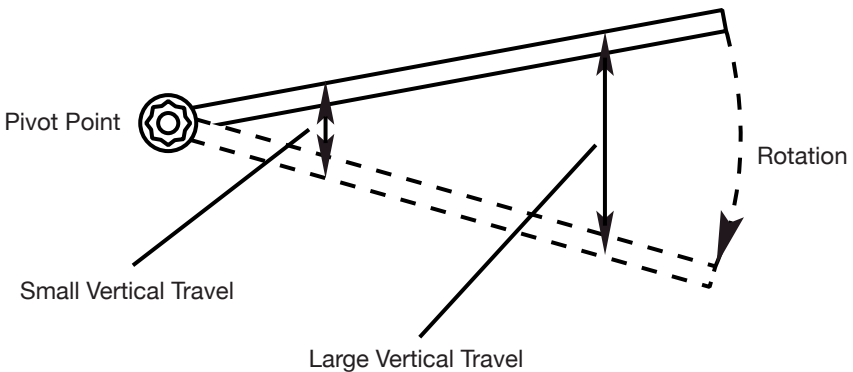

## Height Sensor Installation:



**WARNING:** Sensor travel is limited to 2.75". Over extension or over compression will damage the sensor.

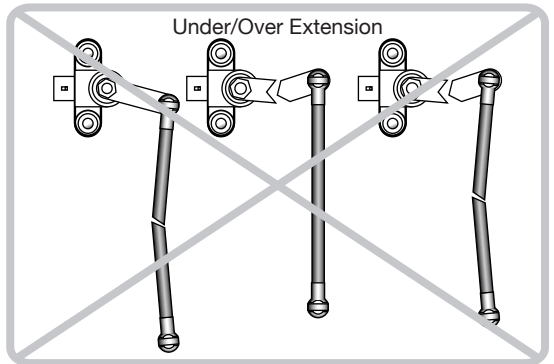
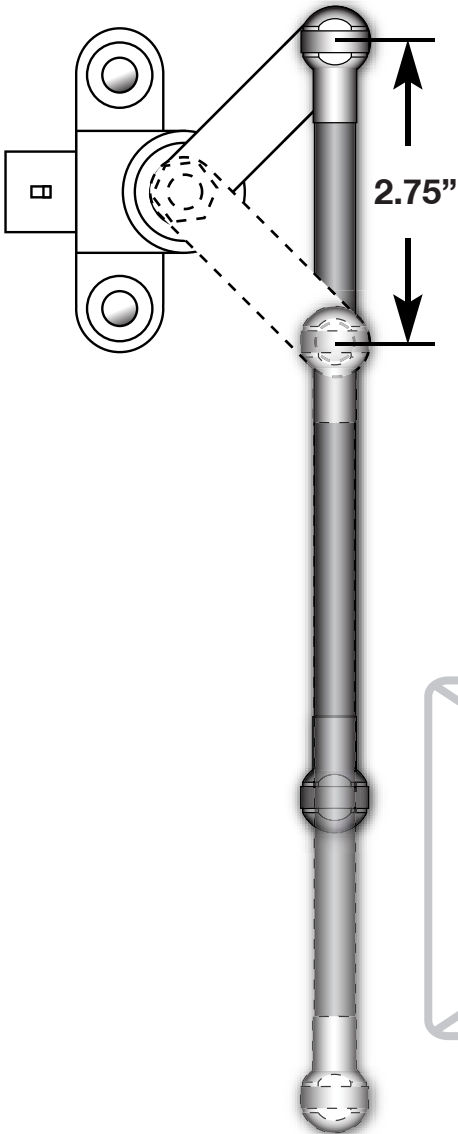

## Height Sensor Installation:

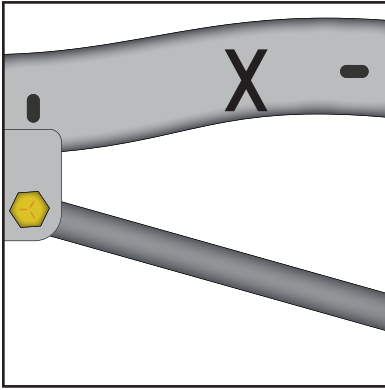

**Step 1.)** Choose a stationary mounting point on the frame where you hope to mount the sensor, (Mark an “X” here). All of the following measurements will be taken from this point.

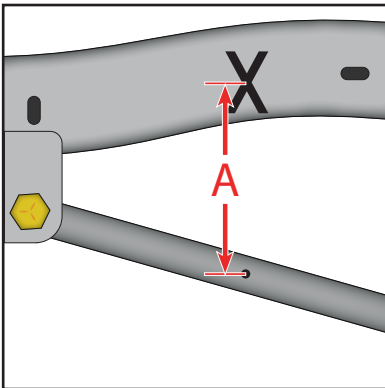

**Step 2.)** Mark a Dot on the moving suspension arm directly under the “X” from step 1, (This will be your target ball stud mounting point). With the vehicle at the top of its travel (aired all the way up), measure from your dot up to the center of your “X”. We will call this distance “A”.

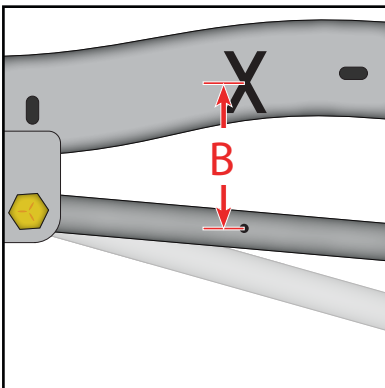

**Step 3.)** While standing clear, exhaust the vehicle to the very bottom of its travel. Now re-measure from your dot up to the center of your “X”. We will call this distance “B”.

Calculate the sensor travel by subtracting B from A, (Sensor Travel = A-B).

## Height Sensor Installation:

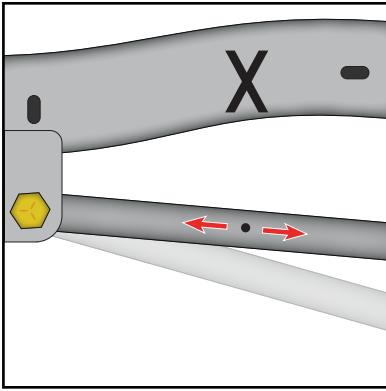

**Step 4.)** If your sensor travel is less than 2.75" then move further away from the pivot point of your suspension arm and repeat steps 1 through 3. If your sensor travel is more than 2.75" then move closer toward the pivot point of your suspension arm and repeat steps 1 through 3.

**(We understand that getting the sensor travel right on 2.7500" is not possible, so make the travel less than 2.75" rather than greater than 2.75" when you come to this point.)**

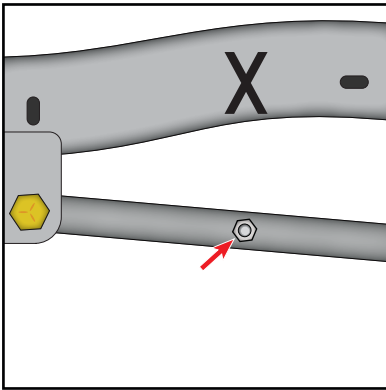

**Step 5.)** Once you have established your ball stud mounting point that yields 2.75" of sensor travel drill or weld to attach the supplied ball stud at this exact point.

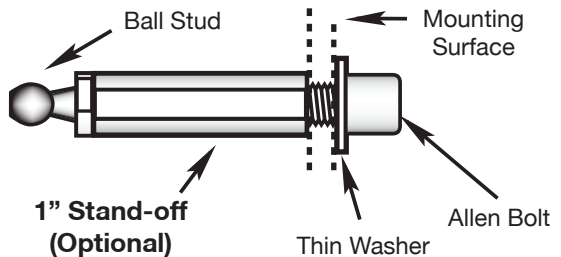



## Height Sensor Installation:

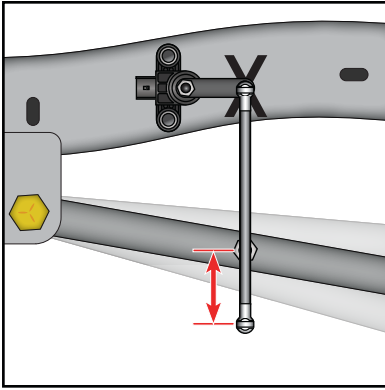

**Step 6.)** With the sensor linkage installed on the sensor arm and the vehicle at the middle of the travel, hold the sensor apparatus up as if it were attached to the ball stud that you installed in Step 5. Determine if you will need to shorten the linkage. If not continue to step 8. If so unscrew the end-links and cut the threaded rod, (Make sure to restart the threads nicely). Then cut the plastic tubing 5/8" shorter than your new total rod length, (you want 5/16" worth of thread engagement on each end). Then re-assemble the

rod. Note that the end links do not need to get tight on the rod, because once installed the ball stud prevents them from rotating loose.

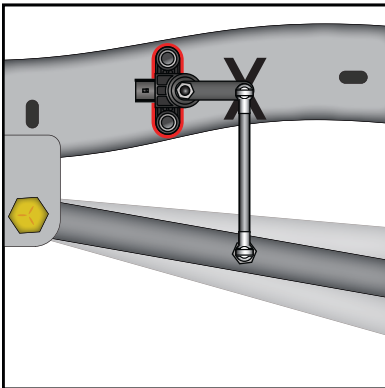
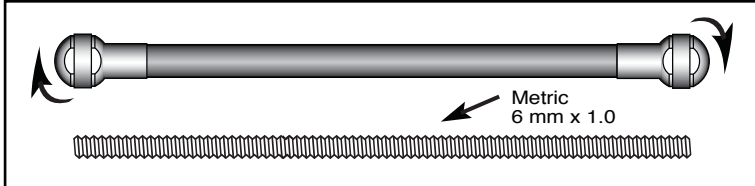

**Step 7.)** Attach the lower end-link to the ball stud. With the vehicle about half way through the travel, find the exact sensor mounting point that keeps the mounting holes and linkage rod vertical. Once established, trace the outline of the sensor to the frame.

## Height Sensor Installation:

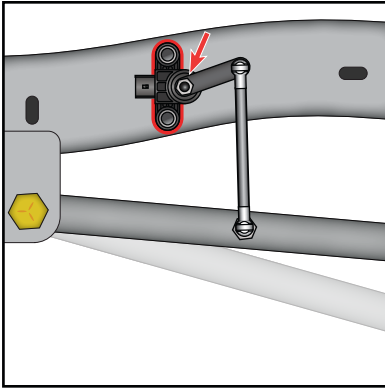

**Step 8.)** With the vehicle at the very bottom of the travel, hold the sensor at the same location traced on the frame in step 7. Either rotate the sensor slightly, or adjust the linkage so that there is about 1/4" of clearance between the upper plastic stop and the rotating arm. Visually note this amount.

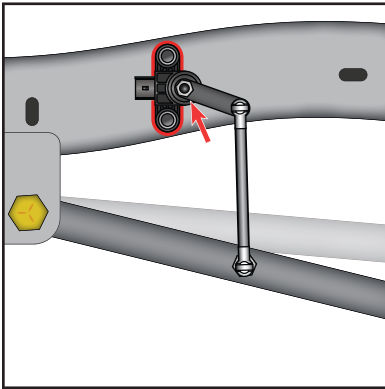

**Step 9.)** With the vehicle at the very top of the travel, compare the clearance found in step 8, to the clearance between the lower plastic stop and the rotating arm. Repeat Step 8 and 9 until the upper and lower clearance is approximately equal.

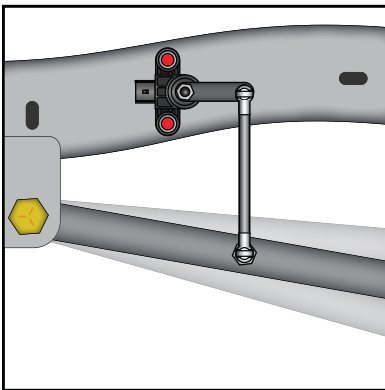

**Step 10.)** Use the final sensor location to mark the two mounting holes to be drilled through the frame. Drill the holes and install the sensor mounting hardware. **(BE CAREFUL NOT OVER TIGHTEN!)**

**Step 11.)** Now that the sensor is mounted, repeat Step 8 and Step 9 to make sure that the clearance is still equal. Adjust the linkage if necessary.

## Height Sensor Installation:

**⚠ NOTE:** It is **EXTREMELY** important to wire the Ride-Height Sensors correctly. Identify the number label on each sensor cable and route it to the correct corner of the car based on the system diagram in the front of this manual.

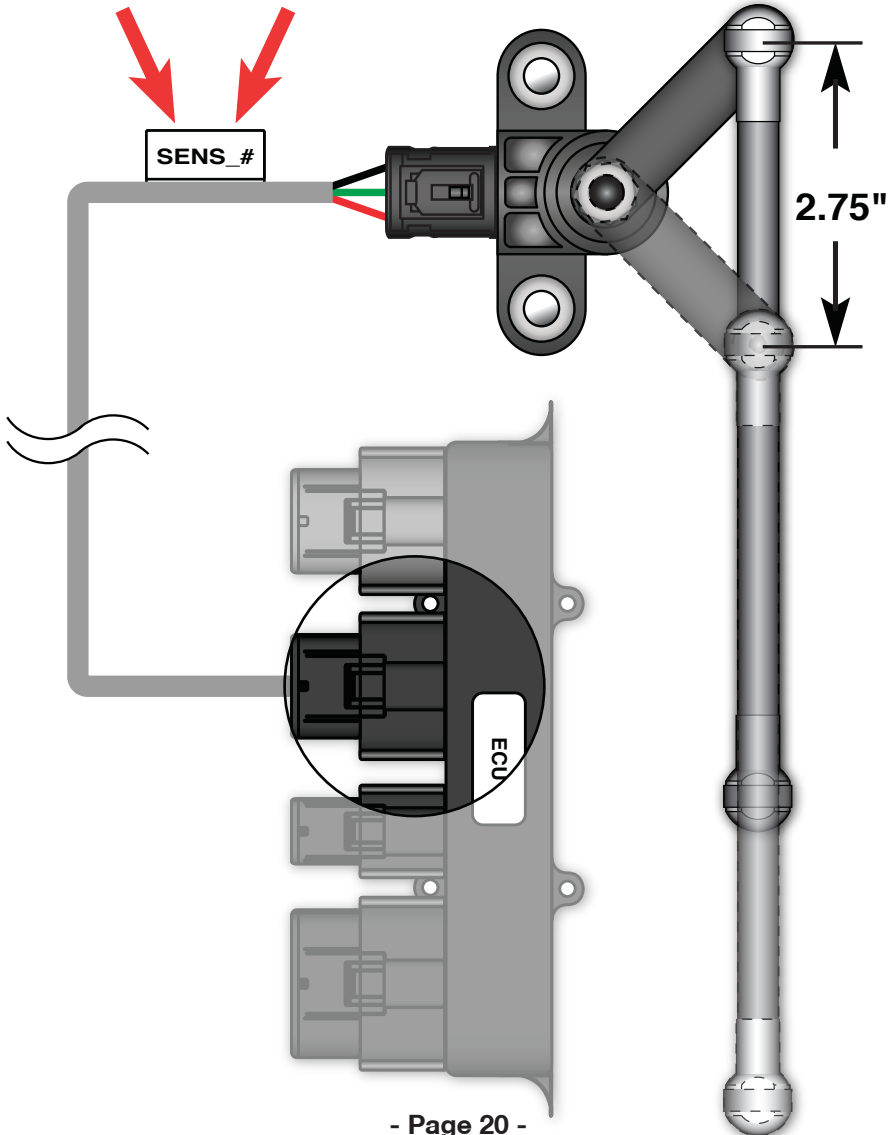



## Setup Programming:

### System Calibration

Refer to your OPERATION MANUAL for the System Calibration Procedure.



**Mounting Templates:**

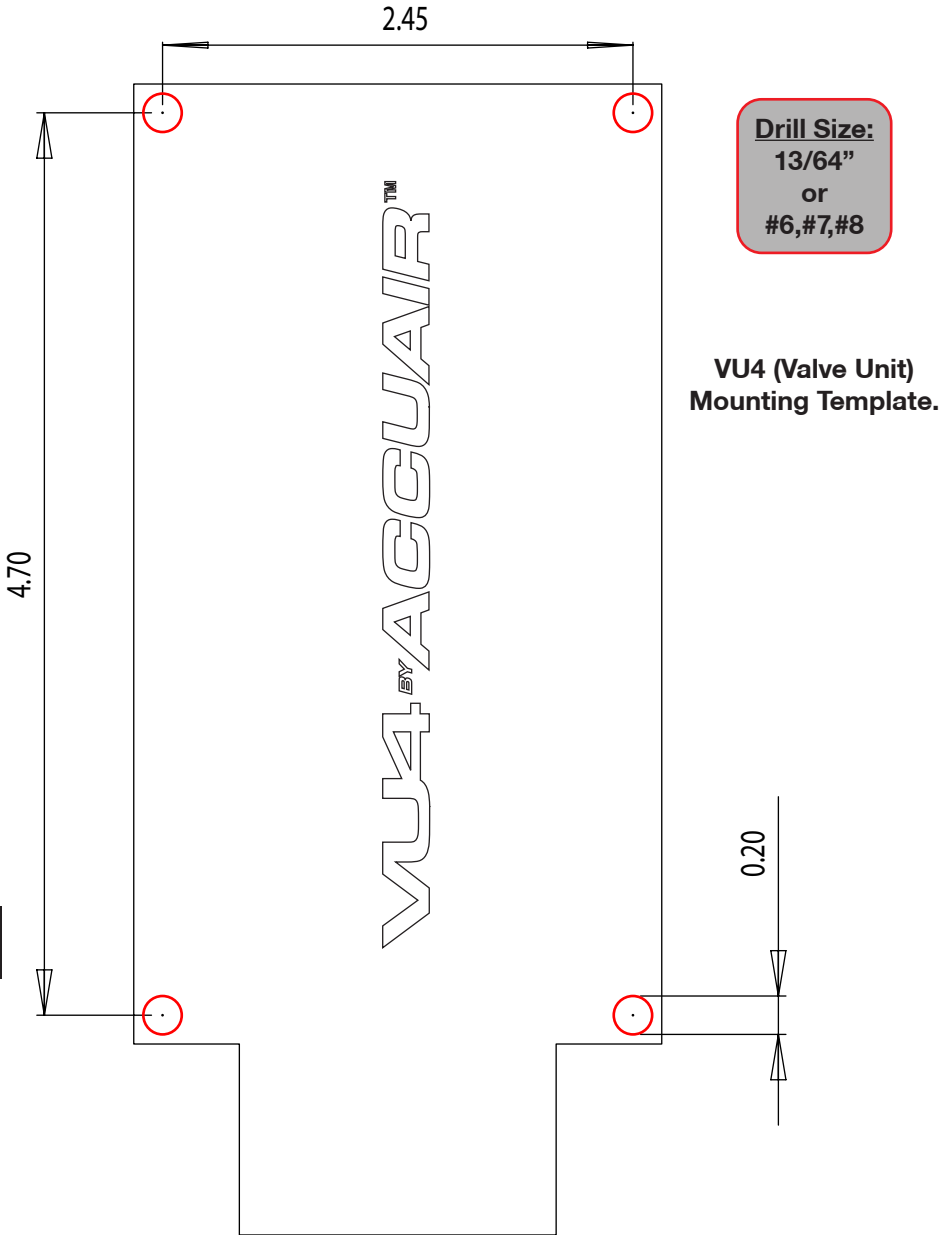



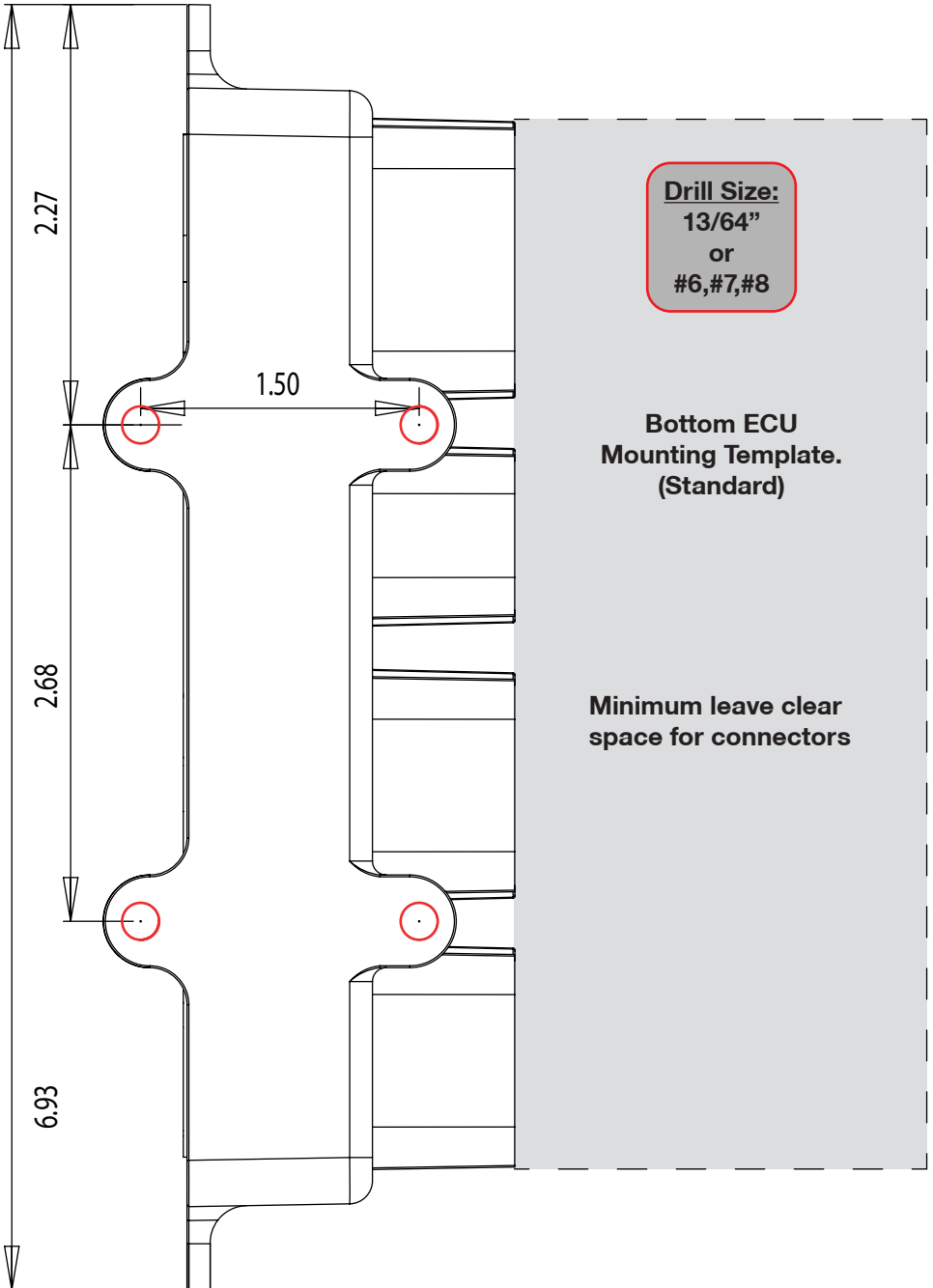





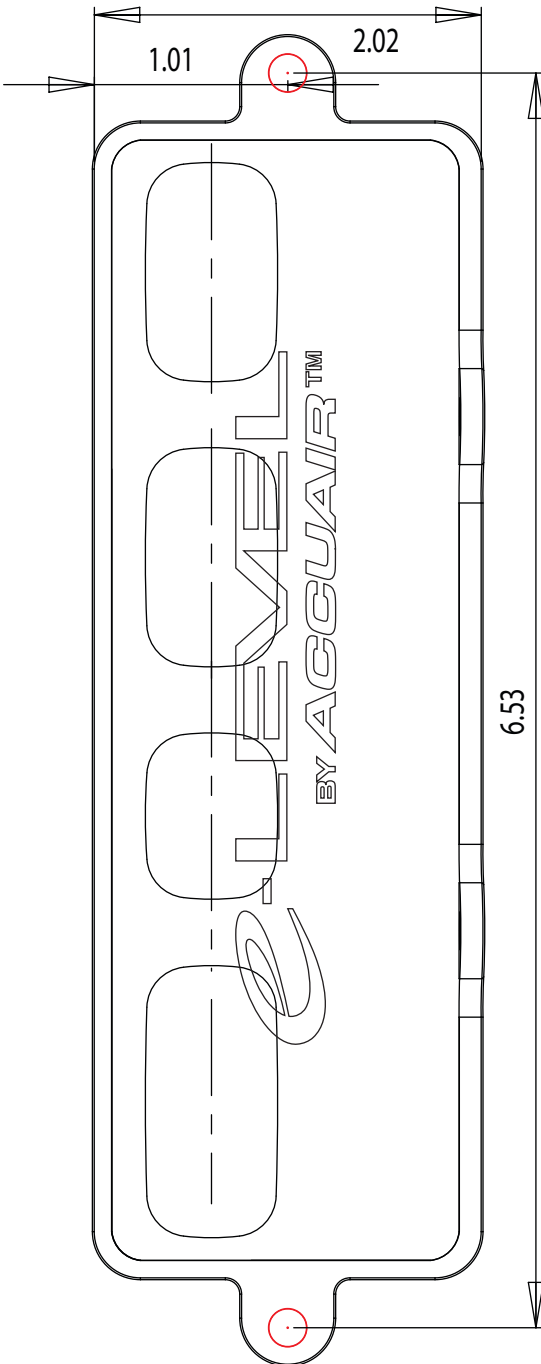

**Drill Size:**  
**13/64"**  
**or**  
**#6,#7,#8**

**Rear ECU  
Mounting Template.  
(Optional)**



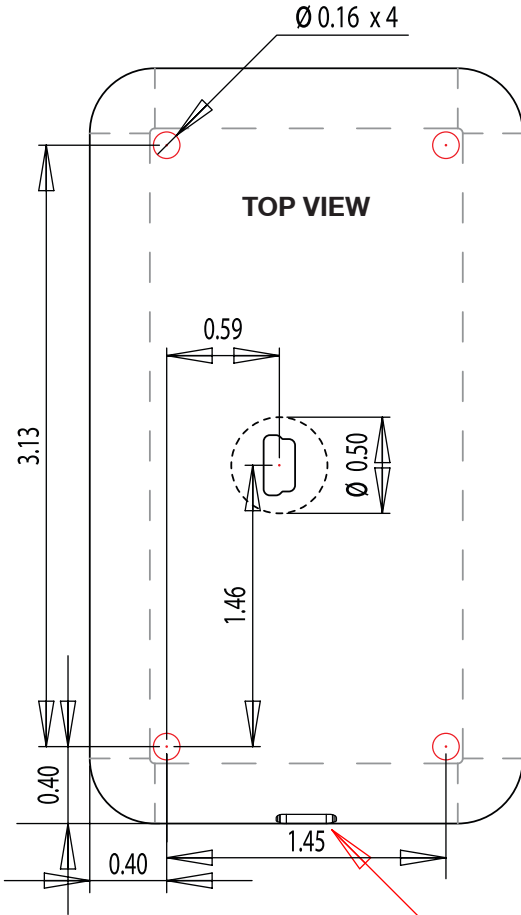

**Drill Size:**  
**5/32"**

**TouchPad™  
Mounting Template.**

**Bottom Side with  
USB Connector**