

# e-Level™ Electronic Leveling System 4-Corner Package w/ TouchPad™

# AA-ELS4-TPAD



Since its release, the e-Level™ Controller has become the industry favorite for accuracy, reliability, and ease-of-use. It offers the ability to save three unique heights into memory at the touch of a button using TruPosition™ height sensors installed in each corner of your suspension. The key to this technology is its RideMonitor™ Mode; while parked or driving, the system will maintain the vehicle height when loading or unloading passengers or when road conditions change. All of this automatic intelligence is unnoticed by the driver, providing improved ride quality and handling characteristics for any vehicle with Air Suspension. Each system calibrates to the vehicle upon installation and then learns how your Air Suspension behaves over time. This flexibility allows the e-Level™ Controller to be used on ANY vehicle and requires NO user tuning.

Operation of the e-Level™ system is simple, yet its features are constantly working to provide you with the perfect ride-height in all conditions. Because the e-Level™ system utilizes height sensors instead of pressure sensors, changes in load are accurately corrected for. The adjustments made by an e-Level™ controller are so accurate that each wheel maintains its height within 1/8<sup>th</sup> of an inch and actually prevents cross-loading of air springs at a higher accuracy than any other method (Read "[Air on Scales](#)"). This is all made possible because the system calibrates to the vehicle upon installation and then learns how your air suspension behaves over time (similar to the technology used in today's advanced fuel injection systems). This flexibility allows the e-Level™ controller to be used on any vehicle with a wide variety of valve speeds and requires NO user tuning. In addition to managing the height of your air springs, the e-Level™ system also manages your air compressor(s). A 0-200 psi sealed tank pressure sensor lets the ECU know the constant status of the air tank. This eliminates the use of a mechanical pressure switch and lets the e-Level™ system manage your compressor(s) more efficiently. Constant self diagnostics monitor every component in the system and notify the user if a problem occurs. The e-Level™ system also constantly monitors the status of your vehicle's batteries and automatically turns the compressor(s) OFF if the system voltage drops below 10.5 volts.

## Features:

- **3 Programmable Heights** Lowered / Ride Height / Raised.
- **RideMonitor™ Mode** adjusts as needed while driving or parked.
- **TruPosition™ Height Sensors** provide accurate leveling regardless of load.
- **Ride-Height-on-Start** gets you ready to drive when you turn the key.
- **Anti "Cross-loading" Height Management** gives balanced spring weights.
- **TouchPad™** accesses your 3 programmable heights and controls each individual air spring or front and rear as a pair.
- **Key-Chain Remote** (optional) accesses your 3 programmable heights from up to 200 ft away.
- **Automatically Calibrates** to any Air Suspension System on any vehicle, (NO user programming required).
- **Straight to Height adjustments** avoid valve "pulsing" and gets you ready to drive immediately.
- **Active Learning** maximizes leveling performance after every adjustment.
- **Manages Air Compressors** for faster height recovery.
- **Monitors Vehicle Voltage** and automatically turns compressor(s) OFF at 10.5 volts to prevent a dead battery.
- **100% Weather-Proof** for under vehicle mounting.
- **Plug-n-Play** wiring harnesses for ease of installation.
- **Each System is 100% Factory Tested.**



# AA-ELS4-TPAD

## e-Level™ Electronic Leveling System 4-Corner Package w/ TouchPad™

### TouchPad™ Finish Options:

Electroless Nickel



Black Anodize

INDIVIDUAL  
CORNER CONTROL

3 SAVABLE HEIGHTS

ie. • LOWERED  
• RIDE HEIGHT  
• RAISED

ALL-DOWN

PAIRED  
CONTROLS



### TouchPad™:

For the ultimate in form and function, the intuitive TouchPad™ is the top of the line interface option. Handheld or mountable, the TouchPad™ is available in black-anodize or nickel-plated aluminum and gives full manual control of each air spring individually as well as front and rear air spring control in "pairs". Saving and accessing your three preset heights is only a touch away and a clean yellow glowing ring around each button clearly indicates the current vehicle height. The "All-Down" button fully deflates the vehicle for parking. Every button offers a "crisp" tactile feel and is backlit with crystal white LED's for clear daytime and nighttime operation. A 20 ft mini-USB cable provides communication to the ECU and plugs into the TouchPad™ in either the bottom or the back.

All wiring harnesses are color-coded and Plug-n-Play for quick and error-free installation.

### Optional Accessories:

#### Wireless Key-Fob



Kit Includes:	Qty	PN
Electronic Control Unit (ECU)	1	AA-EC4
Touchpad™ Controller (Electroless Nickel Finish) w/ 20 ft USB Cable	1	AA-TPAD-E
OR or Touchpad™ Controller (Black Anodize Finish) w/ 20 ft USB Cable		AA-TPAD-B
Ride Height Sensors w/ Linkage	4	AA-SENSKIT
4-Corner Height Sensor Harness (20/20/16/16 ft)	1	AA-H-SENS4
4-Corner Solenoid Valve Harness (1 ft Pigtail)	1	AA-H1-ECV4-P
Main Power Harness w/ Built In Fuses	1	AA-H-MAIN-TPAD
0-200 psi Tank Pressure Sensor	1	AA-PSENS-200
Stainless Steel Mounting Hardware Package	1	AA-HW-ELS-TPAD
Illustrated Installation & Operation Manuals	1	AA-INST-ELS4-TPAD

Optional Accessory Items:	Qty	PN
Wireless Key-Fob Module	1	AA-RF-FOB

Technical Specifications:	
Compatible Suspension Type	4-Corner Full Air Suspension (any brand, any vehicle)
No. of Savable Heights	3 & All-Down
Voltage Requirements	9.5-16 Volts
Current Requirements	15 Amps (Max)
Valve Output	(8) 12-volt solenoid valves up to 3 Amps each (any brand)
Compressor Output	3-Amps Max
Tank Pressure Range	110 psi ON; 150 psi OFF
Connectors	IP67 certified (immersion up to 3 ft)
TouchPad™ Connector	USB – Mini B
Position Accuracy	1/8" at wheel while parked or driving
Leveling Response Time	5 seconds parked / 45 seconds driving
Auxiliary Device Compatibility	- TouchPad™ Interface - Rocker Switch Interface - Wireless Key-Fob Module - (4) Universal "GND-trigger" Inputs for use with customer supplied alarm, or other device. Triggers 3 Heights & All-Down
Compatibility available upon request	- Horizon Leveling Module - CANbus protocol for use with customer specific interfaces



# e-Level™ Electronic Leveling System 4-Corner Package w/ TouchPad™

# AA-ELS4-TPAD

Dimensions In Inches (Not To Scale) TouchPad™ CONTROLLER

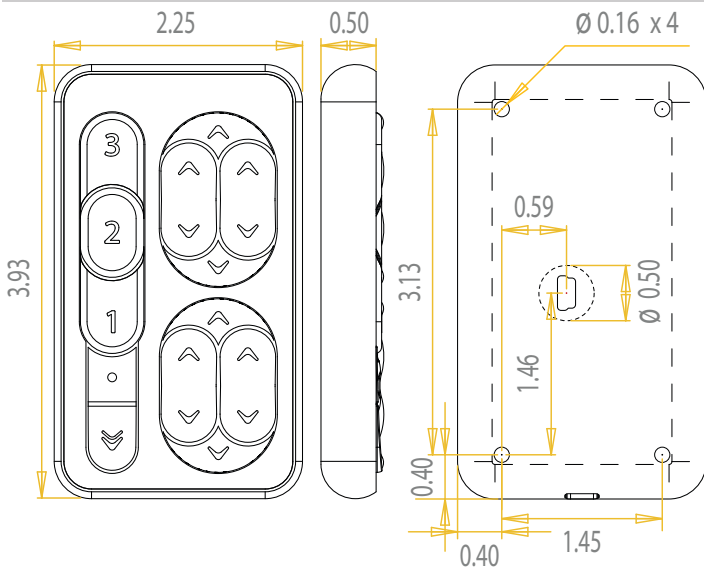

Dimensions In Inches (Not To Scale) TANK PRESSURE SENSOR

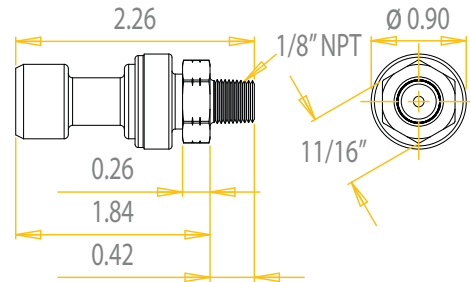

Dimensions In Inches (Not To Scale) RIDE HEIGHT SENSOR

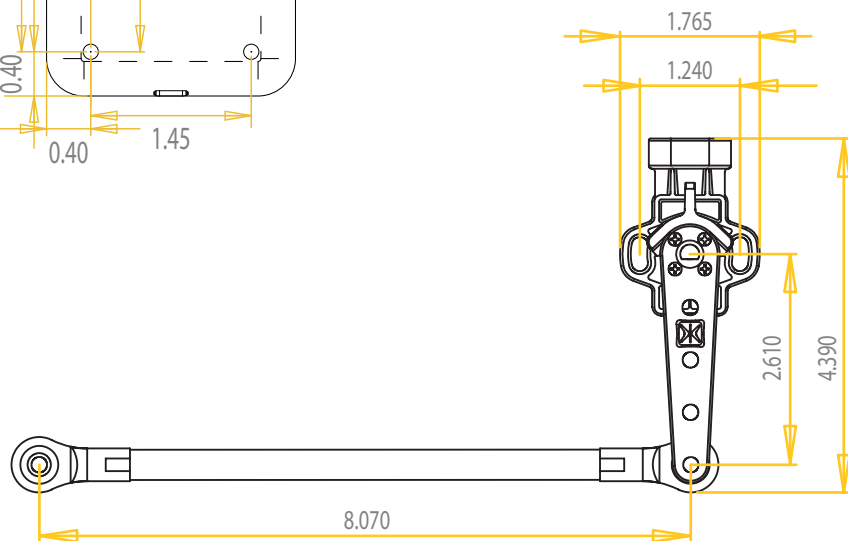

Dimensions In Inches (Not To Scale)

ECU

